

DC Axial Fans



FSY12X12L(M)(H) FSY12X24L(M)(H) FSY12X48L(M)(H)

Features

Size: 120×120×25mm(4.72×4.72×1.00in)

Frame/Impeller: Reinforced Plastic UL94V-0

Bearings: Ball Bearing&Sleeve Bearing

Life Expectancy: 50,000 Hours at 20°C-Ball
30,000 Hours at 20°C-Sleeve

Approvals: UL CUL TUV CE RoHS

Weight: 145g

E318377 CE TUV AE50078978

▪ RoHS Compliant

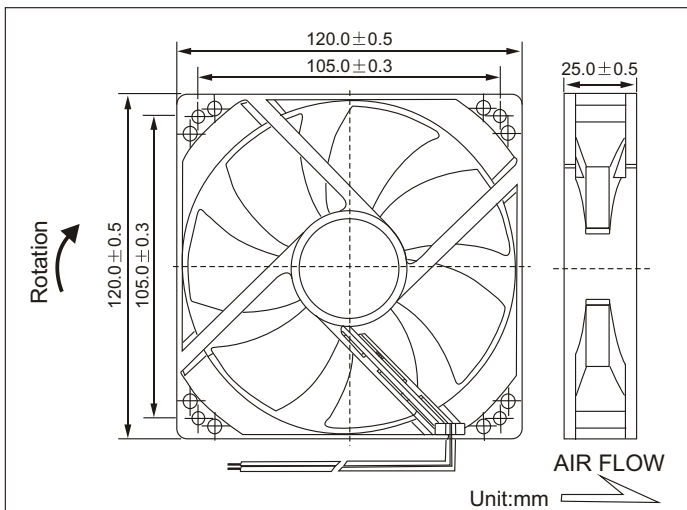

Air Flow vs Air Pressure

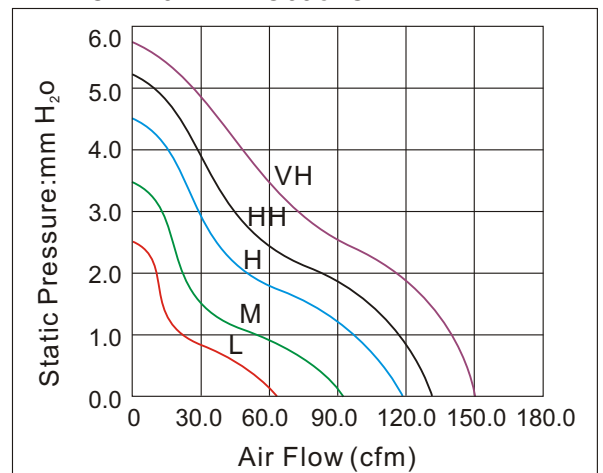

Performance

Model	Bearing System			Rated Voltage (V)	Current (A)	Input Power (W)	Nominal Speed (R.P.M)	Air Flow (CFM)	Air Pressure (mm-H ₂ O)	Noise (dBA)
	S	B	D							
FSY12X12L	✓	✓	✓	12	0.15	1.80	1800	68.45	2.68	32
FSY12X12M	✓	✓	✓	12	0.25	3.00	2500	92.52	3.65	36
FSY12X12H	✓	✓	✓	12	0.35	4.20	3000	114.00	4.45	41
FSY12X12HH	✓	✓	✓	12	0.45	5.40	3500	133.05	5.21	45
FSY12X12VH	✓	✓	✓	12	0.55	6.60	4000	150.11	5.82	50
FSY12X24L	✓	✓	✓	24	0.10	2.40	1800	68.45	2.68	32
FSY12X24M	✓	✓	✓	24	0.18	4.32	2500	92.52	3.65	36
FSY12X24H	✓	✓	✓	24	0.25	6.00	3000	114.00	4.45	41
FSY12X24HH	✓	✓	✓	24	0.35	8.40	3500	133.05	5.21	45
FSY12X24VH	✓	✓	✓	24	0.45	10.80	4000	150.11	5.82	50
FSY12X48M	✓	✓	✓	48	0.10	4.80	2500	92.52	3.65	36
FSY12X48H	✓	✓	✓	48	0.15	7.20	3500	133.05	5.21	45