

| Type | $I_{F(AV)}$ | | V_{FM}/I_{FM} | | $I_{F(RMS)}$ | V_{RRM} | I_{RRM} | R_{θ} | T_J | M^2 | Wt | Outline |
|-----------|---------------------|------|-----------------|-------|--------------|-----------|---------------|--------------|------------------|------------|-------|---------|
| | $T_{HS55}^{\circ}C$ | | 25 $^{\circ}C$ | | | | | | | | | |
| | A | V | A | A | V | mA | $^{\circ}C/W$ | $^{\circ}C$ | N/m | kg | | |
| 6F(R) | 6 | 1.1 | 18 | 9.0 | 200-1200 | ≤ 6 | ≤ 2.0 | | | ≤ 1.0 | 0.008 | DO-4 |
| 12F(R) | 12 | 1.25 | 36 | 19.0 | 200-1200 | ≤ 6 | ≤ 1.2 | | | ≤ 1.0 | 0.008 | |
| 16F(R) | 16 | 1.25 | 48 | 25.0 | 200-1200 | ≤ 12 | ≤ 1.2 | | | ≤ 1.0 | 0.008 | |
| 25F(R) | 25 | 1.1 | 75 | 40.0 | 200-1200 | ≤ 12 | ≤ 1.2 | | | ≤ 1.0 | 0.008 | |
| 30HF(R) | 30 | 1.3 | 90 | 48.0 | 200-1200 | ≤ 10 | ≤ 0.8 | | | ≤ 2.0 | 0.020 | DO-5 |
| 40HF(R) | 40 | 1.3 | 120 | 64.0 | 200-1200 | ≤ 10 | ≤ 0.8 | | | ≤ 2.0 | 0.020 | |
| 50HF(R) | 50 | 1.4 | 150 | 80.0 | 200-1200 | ≤ 10 | ≤ 0.8 | | | ≤ 2.0 | 0.020 | |
| 60HF(R) | 60 | 1.4 | 180 | 96.0 | 200-1200 | ≤ 12 | ≤ 0.6 | | | ≤ 2.0 | 0.020 | |
| 70HF(R) | 70 | 1.45 | 210 | 112.0 | 200-1600 | ≤ 12 | ≤ 0.5 | | -40 $^{\circ}C$ | ≤ 2.0 | 0.020 | DO-8 |
| 85HF(R) | 85 | 1.45 | 255 | 136.0 | 200-1600 | ≤ 12 | ≤ 0.4 | | ~ | ≤ 2.0 | 0.020 | |
| 100U(R) | 100 | 1.8 | 300 | 160.0 | 200-1600 | ≤ 15 | ≤ 0.3 | | +150 $^{\circ}C$ | ≤ 12 | 0.120 | |
| 150U(R) | 150 | 1.5 | 450 | 240.0 | 200-1600 | ≤ 15 | ≤ 0.3 | | | ≤ 12 | 0.120 | |
| 100U(R)L | 100 | 1.8 | 300 | 160.0 | 200-1600 | ≤ 15 | ≤ 0.3 | | | ≤ 12 | 0.140 | DO-30 |
| 150U(R)L | 150 | 1.5 | 450 | 240.0 | 200-1600 | ≤ 15 | ≤ 0.3 | | | ≤ 12 | 0.140 | |
| 200U(R) | 200 | 1.3 | 600 | 320.0 | 200-1800 | ≤ 20 | ≤ 0.2 | | | ≤ 12 | 0.250 | DO-9 |
| 250U(R) | 250 | 1.35 | 750 | 400.0 | 200-1800 | ≤ 20 | ≤ 0.15 | | | ≤ 25 | 0.250 | |
| 300U(R) | 300 | 1.35 | 900 | 480.0 | 200-1800 | ≤ 20 | ≤ 0.15 | | | ≤ 25 | 0.250 | |
| SD400N(R) | 400 | 1.6 | 1200 | 640.0 | 200-2400 | ≤ 40 | ≤ 0.07 | | | ≤ 25 | 0.580 | B-8 |
| SD500N(R) | 500 | 1.6 | 1500 | 800.0 | 200-2400 | ≤ 40 | ≤ 0.065 | | | ≤ 25 | 0.580 | |
| SD600N(R) | 600 | 1.5 | 1800 | 960.0 | 200-2400 | ≤ 40 | ≤ 0.065 | | | ≤ 30 | 0.580 | |

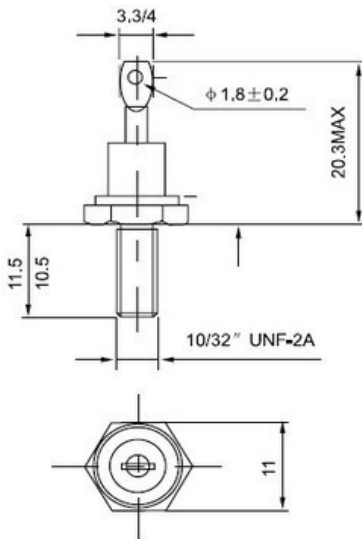

For metric devices: M5 x 0.8
DO-4

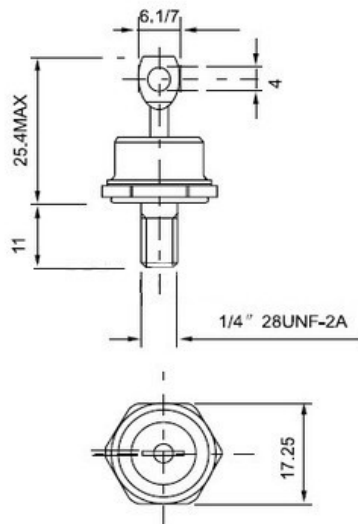

For metric devices: M6 x 1
DO-5

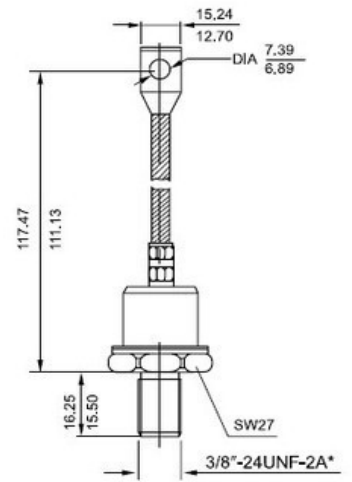

For metric device: M12 x 1.75
DO-8