

Approval Sheet

Customer: _____

Item: _____ High Power LED – 1 W _____

Part No.: _____ WLY28-140-XX1 _____

Customer P/N: _____

Customer Approval



PACKAGE DIMENSIONS

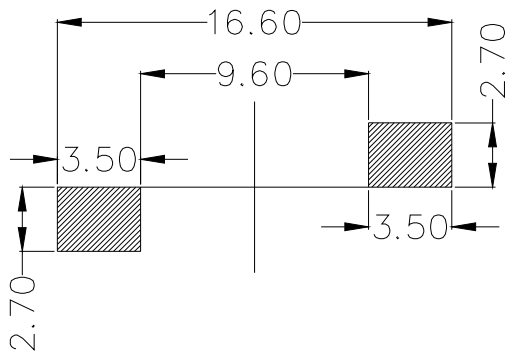
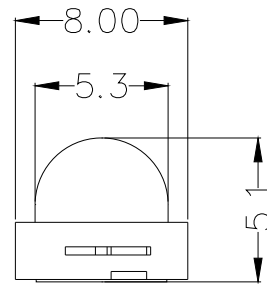
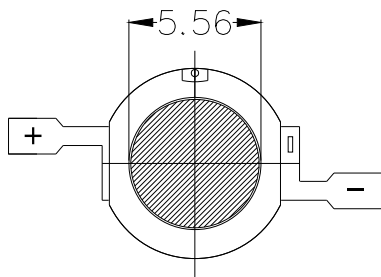
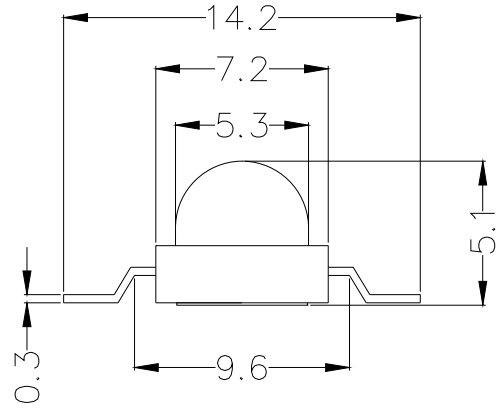
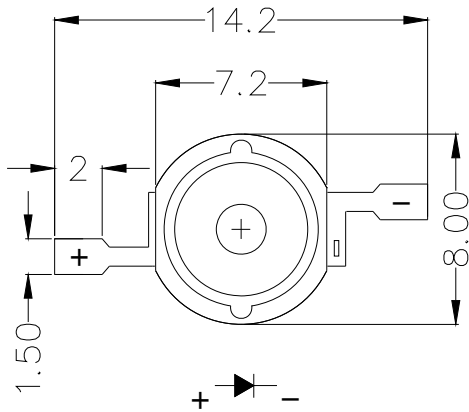

Note:

1. All Dimensions are in millimeters
2. Tolerance is $\pm 0.25\text{mm}$ (0.010") Unless otherwise specified.

Device Selection Guide

Material	Emitting Color	Lens Type
---	Yellow	Water Clear

Absolute Maximum Ratings at Ta=25°C

Parameter	Symbol	Max	Unit
Power Dissipation	P _D	1	W
Peak Forward Current 1/10 Duty Cycle,0.1ms Pulse Width	I _{FP}	500	mA
Continuous Forward Current	I _F	350	mA
Reverse Voltage	V _R	5	V
ESD Sensitivity	ESD	2000	V
Operating Temperature Range	Topr	-40°C to+80°C	
Storage Temperature Range	Tstg	-25°C to+100°C	

Electrical Optical Characteristics at Ta=25°C

Parameter	Symbol	Min	Typ	Max	Unit	Conditio
Forward Voltage	V _F	2.0	2.4	---	V	IF=350mA
luminous flux	I _V	20	30	---	lm	IF=350mA
Dominant Wavelength	λ _d	588	592	---	nm	IF=350mA
Temperature Color	CCT	---	---	---	K	IF=350mA
Reverse Current	I _R	---	---	10	μA	IF=350mA
Viewing Angle	2θ _{1/2}	---	120	---	deg	IF=350mA

Note.

1. 2θ_{1/2} is the off axis angle from lamp centerline where the luminous intensity is 1/2 of the peak value.
2. View angle tolerance is ± 10

Typical Electro-Optical Characteristics Curves

Relative Luminous Intensity vs Forward Current, $T_{Ambient}=25^{\circ}C$

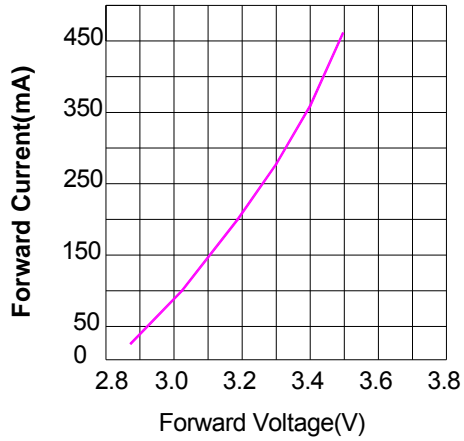

Forward Current Derating Curve, Derating based on $T_{jMAX}=125^{\circ}C$

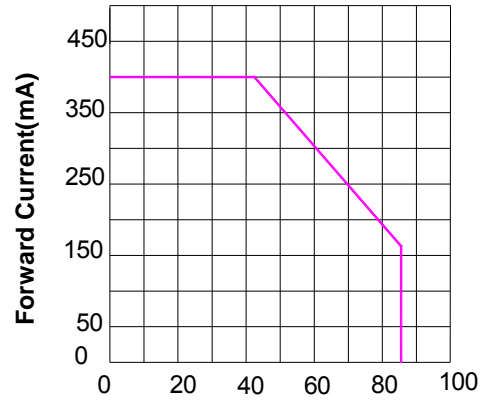

Relative Luminous Intensity vs Forward Current, $T_{Ambient}=25^{\circ}C$

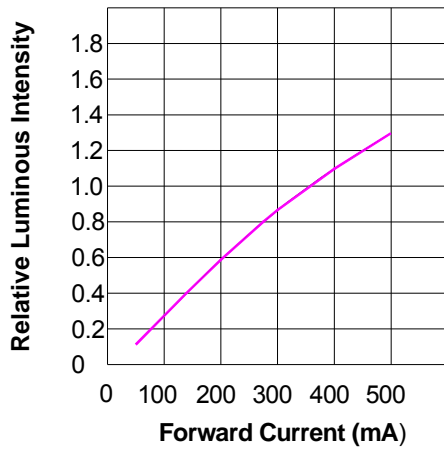

Relative Spectral Distribution, $I_F=350mA$, $T_{Ambient}=25^{\circ}C$

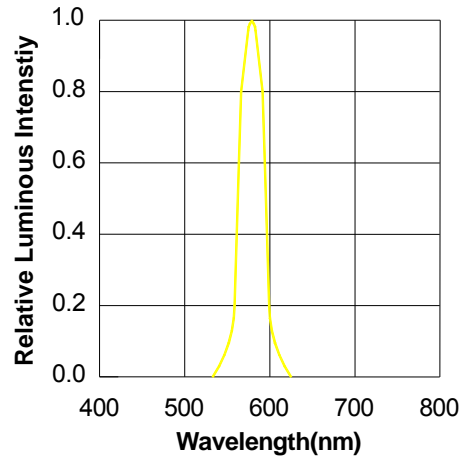

Typical Representative Spatial Radiation Pattern

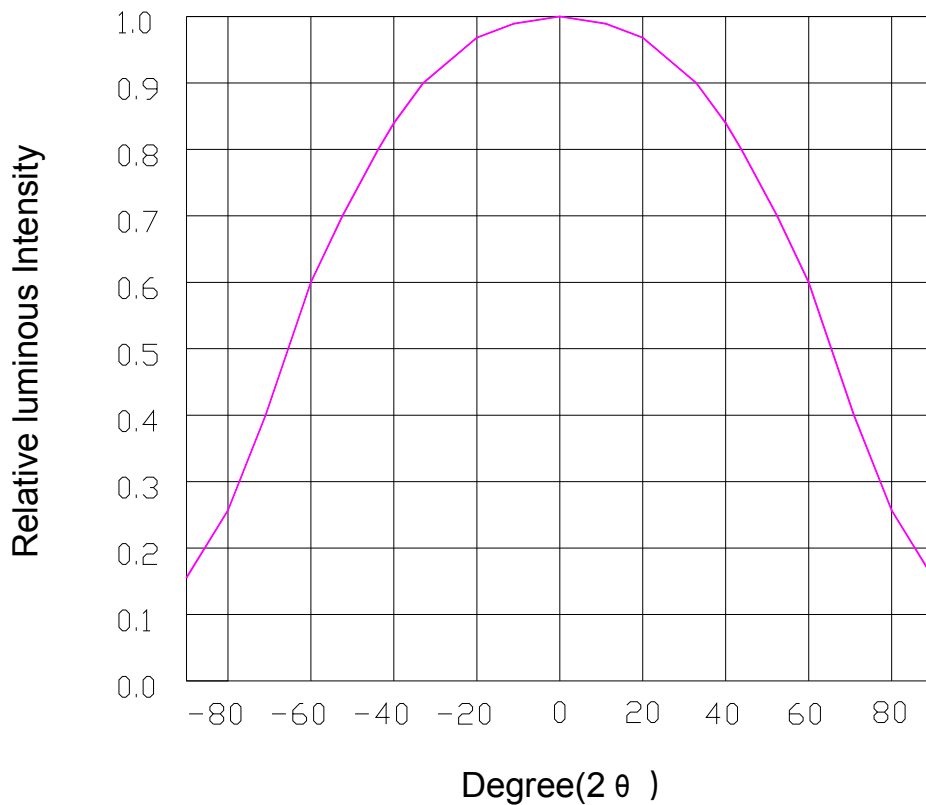

Note.

1. 201/2 is the off axis angle from lamp centerline where the luminous intensity is 1/2 of the peak value.
2. View angle tolerance is ± 10

Luminous Flux Bin Table (lm at 350mA)

BIN	Ld	Le	Lf	Lg
Luminous Flux	20-30	30-40	40-50	50-60

*Measure Uncertainty of Luminous Flux: $\pm 10\%$

Forward Voltage Combination(V at 350mA)

BIN	N	O	P	Q
Forward Voltage	2.0-2.2	2.2-2.4	2.4-2.6	2.6-2.8

*Measure Uncertainty of Forward Voltage: $\pm 0.1V$

Packing Specification

◆Anti-electrostatic bag

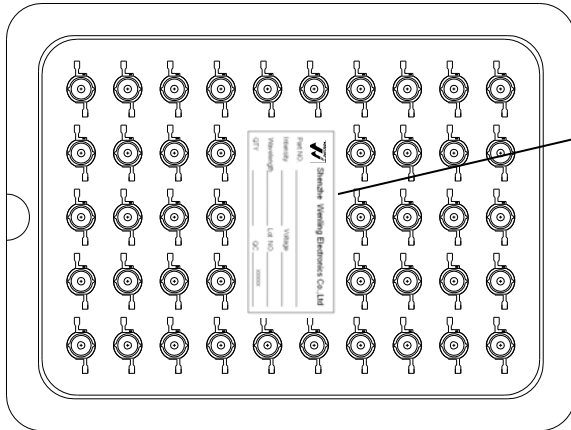

	Shenzhen Wenling Electronics Co.,Ltd
Part NO.	_____
Intensity	_____ Voltage _____
Wavelength	_____ Lot NO. _____
QTY	_____ QC _____ XXXXX

1. Storage

1. Do not open the moisture proof bag before the devices are ready to use.
2. Before the package is opened, LEDs should be stored at temperatures less than 30°C and humidity less than 90%.
3. LEDs should be used within a year.
4. After the package is opened, LEDs should be stored at temperatures less than 30°C and humidity less than 60%.
5. LEDs should be used within 168 hours (7 days) after the package is opened.
6. If the moisture absorbent material (silicone gel) has faded away or LEDs have exceeded the storage time, baking treatment should be implemented based on the following conditions: pre-curing at 60±5°C for 24 hours.

2. Thermal Management

- 1). For maintaining the high flux output and achieving reliability, LEDs should be mounted on a metal core printed circuit board (MCPCB) or other kinds of heat sink with proper thermal connection to dissipate approximately 1W of thermal
- 2). Don't reflow solder.
- 3). Sufficient thermal management must be implemented. Otherwise, the junction temperature of die may exceed over the limit at high current driving conditions and the LEDs' lifetime may be decrease dramatically.
- 4). For further thermal management suggestions, please consult the Wenliang Design Guide or local representatives for assistance.
- 5). Special thermal designs are also recommended to take in outer heat sink design, such as FR4 PCB on Aluminum with thermal vias or FPC on Aluminum with thermal conductive adhesive, etc.

3. Proper Handling

Please do not touch leds as four pictures listed below.

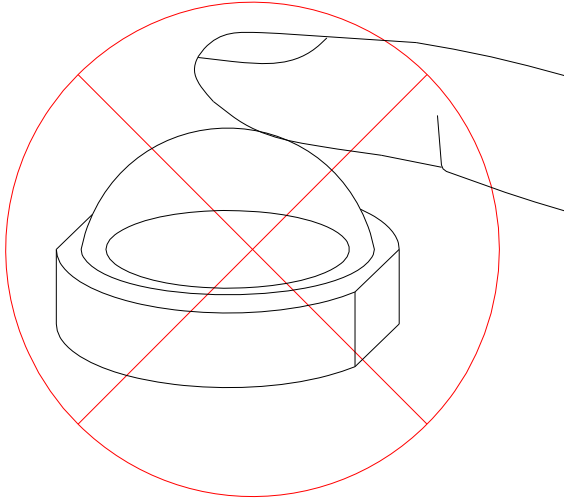

Do not press on the resin directly.

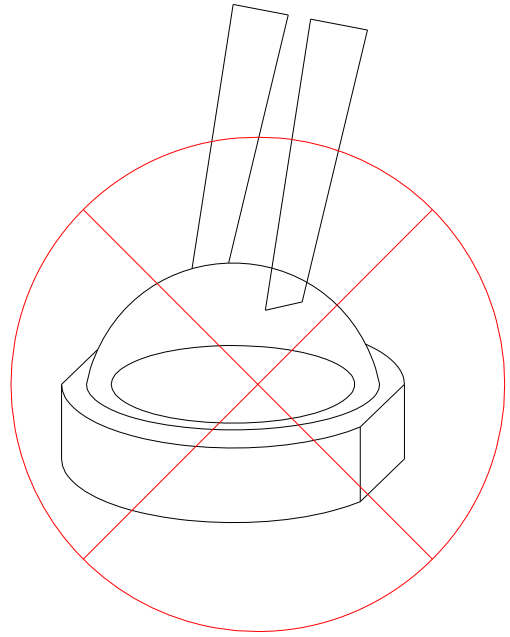

Do not touch the resin.

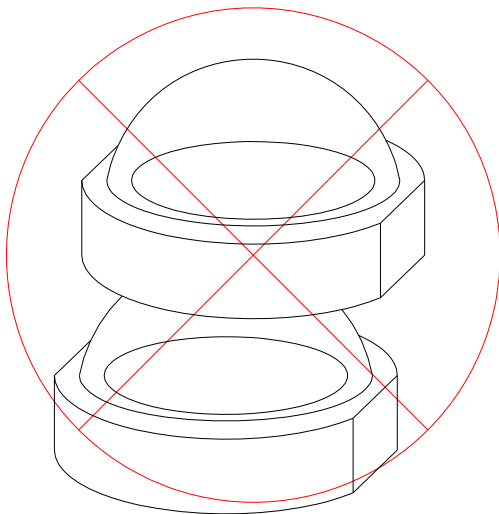

Do not stack the led together.

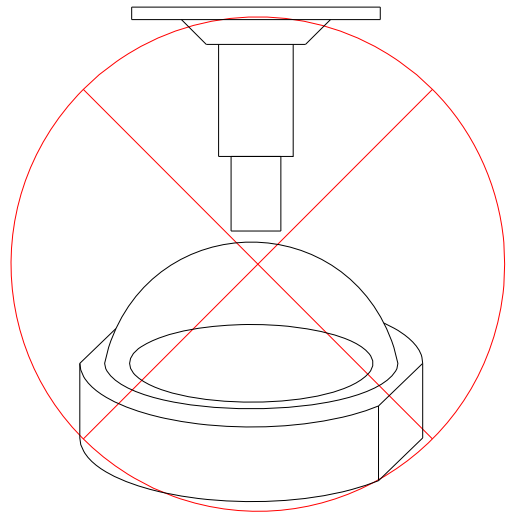

Avoid directly contacting with nozzle.